

A tall, white, rectangular industrial filtration unit. On the left side, there are three circular ports stacked vertically. In the center, there is a small digital display showing 'P 1.2'. To the right, there is a vertical panel with a red emergency stop button and other controls. At the bottom right, there is a large circular outlet. The unit is mounted on a wall with four corner brackets.

MANN+
HUMMEL

ScandMist 200P
Oil fume and VOC
filtration system

ScandMist

NEW

ScandMist 200P

Oil fume & VOC filtration

General	Product	Units	ScandMist 200P
	Application		Rubber & plastic fumes
	Capacity (nominal)	m ³ /h	2000
	Part number		A1B20PB100000A
Connections	Inlet type		Jacobs
	Inlet diameter	mm	200
	Drain		2 off, 2" Threaded (BS 21) Female
	Air inlet options		Left/Right
	Exhaust		Top free blow out and flange back side
Filters	Filters/stage		1
	Stage 1 filter (coalescer)		9709006027
	Stage 2 filter (HEPA H13)		800530024917
	Stage 3 filter (Carboactiv Cube N)		800656024342
	Available external pressure drop	Pa	200
Motor	Type		Electrically commutated
	Part number		9709005278
	Quantity		1
	Mains supply		3 - 380-480 V, 50/60 Hz
	Ventilation		TEFC
	Power	kW	3,7
	Maximum current	A	4,6
	Speed	RPM	Max 4100
	Environmental protection		IP54
Physical properties	Width	mm	773
	Height	mm	1886
	Depth	mm	669
	Weight	kg	Clean filters: 210, Wet filters: 265
	Noise level	dB(A)	<69
	Fan		Backward bent blades
	Finish		Powder coating inside and outside
Controls	Control system		Micaflex MF-PFA
	Differential pressure gauges		3 off
Options	Oil pump		N/A
	Level sensor		9908900187
	Prefilter demister		Included
	Spray		Not included
	Silencer		Insulated fan housing

EC fan and motor

The standard EC fan and motor delivers good energy efficiency with quiet operation.

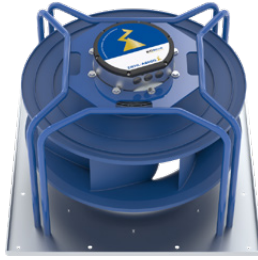

Connecting interface

Wiring via a Harting male/female connector. Quick and easy installation with all connecting interfaces at one spot.

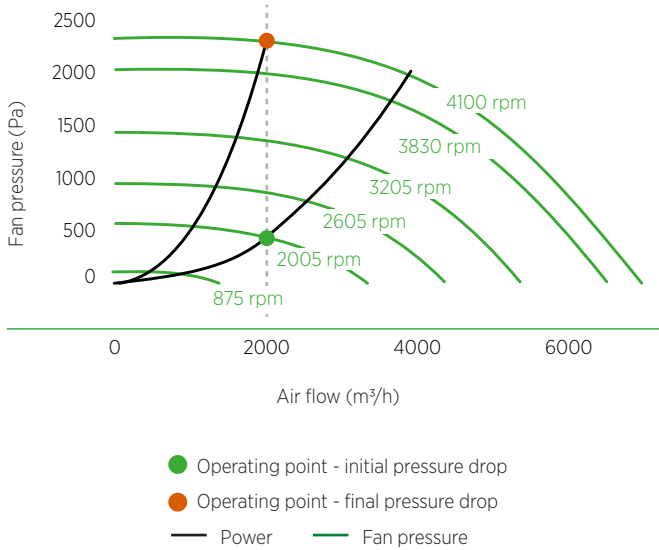

Power		Signal exchange	
1	L1	1	ON/OFF (make contact)
2	L2	2	M
3	L3	3	Output Signal: In Operation
4	N	4	M
5	PE	5	AL1
		6	M
		7	AL2
		8	N
		9	AL3
		10	N
		11	Reset
		12	N
		13	AI2
		14	N

Input: ON/OFF
 Output: In Operation
 Alarm 1, Motor/Power
 Alarm 2, System pressure high/low/operation signal
 Alarm 3, System pressure high/low/operation signal
 Reset for alarms
 Analog output 2 of Micaflex MF-PFA

Dimensions and weight

Units: mm

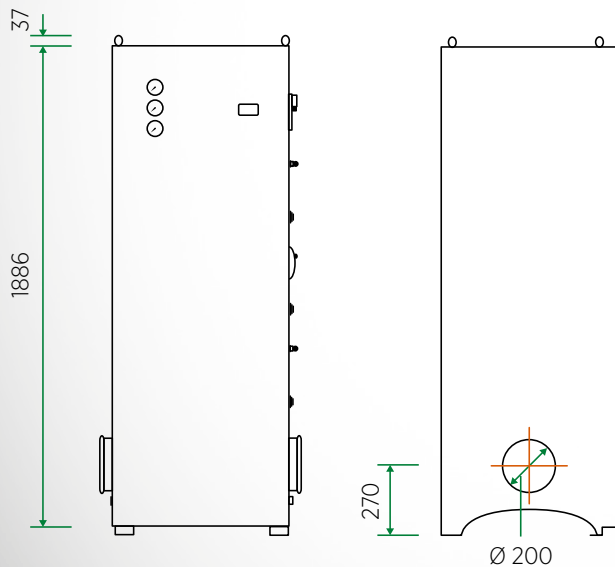

Weight	kg
Empty	155 kg
Clean filters	210 kg
Wet filters	265 kg

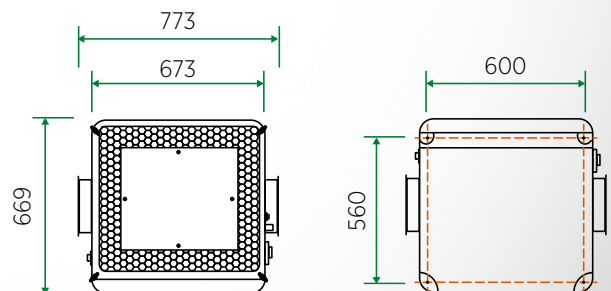



0419 Printed in Germany © MANN+HUMMEL