

A tall, white, rectangular industrial oil and smoke filtration system. The unit features a control panel on the right side with a digital display and several indicator lights. On the left side, there are three circular ports. The unit is mounted on a base with a large circular outlet. The MANN+HUMMEL logo is printed in green on the front panel.

MANN+
HUMMEL

ScandMist 100R
Oil smoke filtration
system

ScandMist

ScandMist 100R

Oil smoke filtration system

General	Product	Units	ScandMist 100R
	Application		Neat oil
	Capacity (nominal)	m ³ /h	1000
	Part number		A1B10RB000000A
Connections	Inlet type		Jacobs
	Inlet diameter	mm	200
	Drain		2 off, 2" Threaded (BS 21) Female
	Air inlet options		Left/Right
	Exhaust		Top free blow out and flange back side
Filters	Filters/stage		1
	Stage 1 filter		9709006037
	Stage 2 filter		9709006038
	Stage 3 filter		800530024917
	Availabl external pressure drop	Pa	200
Motor	Type		Electrically commutated
	Part number		9709005278
	Quantity		1
	Mains supply		3 - 380-480 V, 50/60 Hz
	Ventilation		TEFC
	Power	kW	3,7
	Maximum current	A	4,6
	Speed	RPM	Max 4100
	Environmental protection		IP54
Physical properties	Width	mm	773
	Height	mm	1886
	Depth	mm	669
	Weight	kg	Clean filters: 210, Wet filters: 265
	Noise level	dB(A)	<69
	Fan		Backward bent blades
	Finish		Powder coating inside and outside
Controls	Control system		Micaflex MF-PFA
	Differential pressure gauges		3 off
Options	Oil pump		9708900071
	Level sensor		9908900187
	Prefilter demister		2500273213
	Spray		Not included
	Silencer		Insulated fan housing

*At final pressure drop

EC fan and motor

The standard EC fan and motor delivers good energy efficiency with quiet operation.

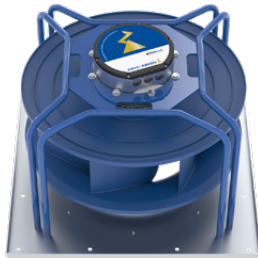

Connecting interface

Wiring via a Harting male/female connector. Quick and easy installation with all connecting interfaces at one spot.

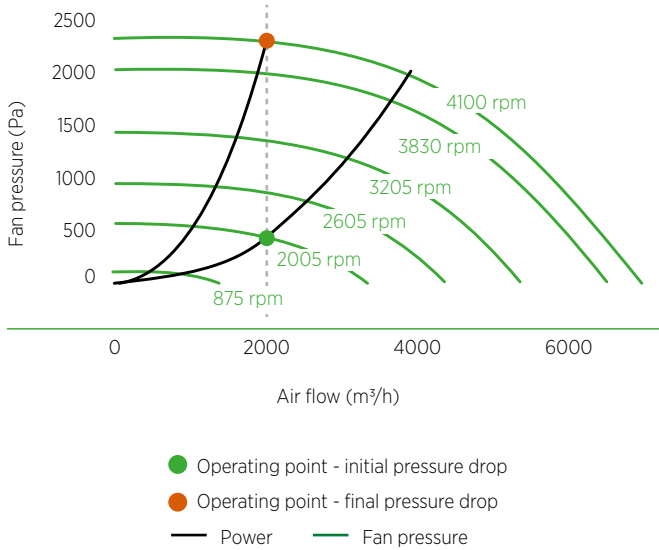

Power		Signal exchange	
1	L1	1	ON/OFF (make contact)
2	L2	2	M
3	L3	3	Output Signal: In Operation
4	N	4	M
5	PE	5	AL1
		6	M
		7	AL2
		8	N
		9	AL3
		10	N
		11	Reset
		12	N
		13	AI2
		14	N

Input: ON/OFF
 Output: In Operation
 Alarm 1, Motor/Power
 Alarm 2, System pressure high/low/operation signal
 Alarm 3, System pressure high/low/operation signal
 Reset for alarms
 Analog output 2 of Micaflex MF-PFA

Dimensions and weight

Units: mm

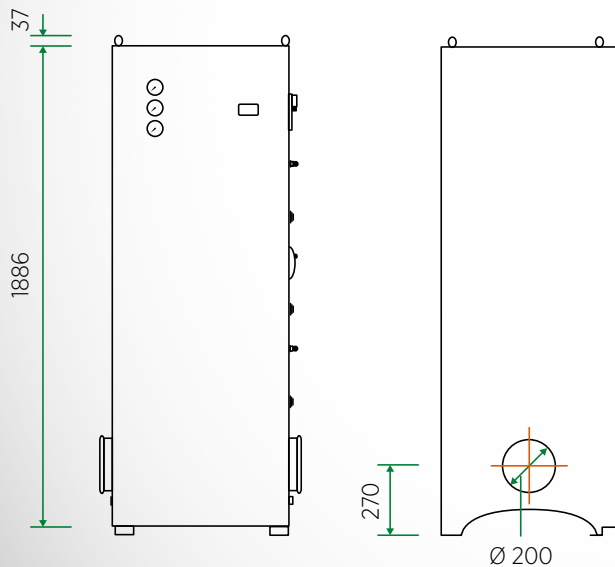

Weight	kg
Empty	155 kg
Clean filters	210 kg
Wet filters	265 kg

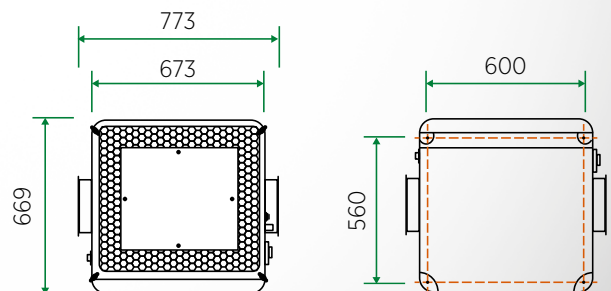



0519 Printed in Germany © MANN+HUMMEL