

Microbarrier HEPA HT/ HEPAMAX™ HT High Temperature HEPA's

FEATURES

- Rated up to 500 °F (260 °C)
- Quality controlled manufacturing facility
- Fiberglass microfiber media packs
- Rolled & tapered aluminum separators
- Available efficiencies from 99.97% to 99.99% @ 0.3 µm
- Available in standard & high flow models
- Gasket seal

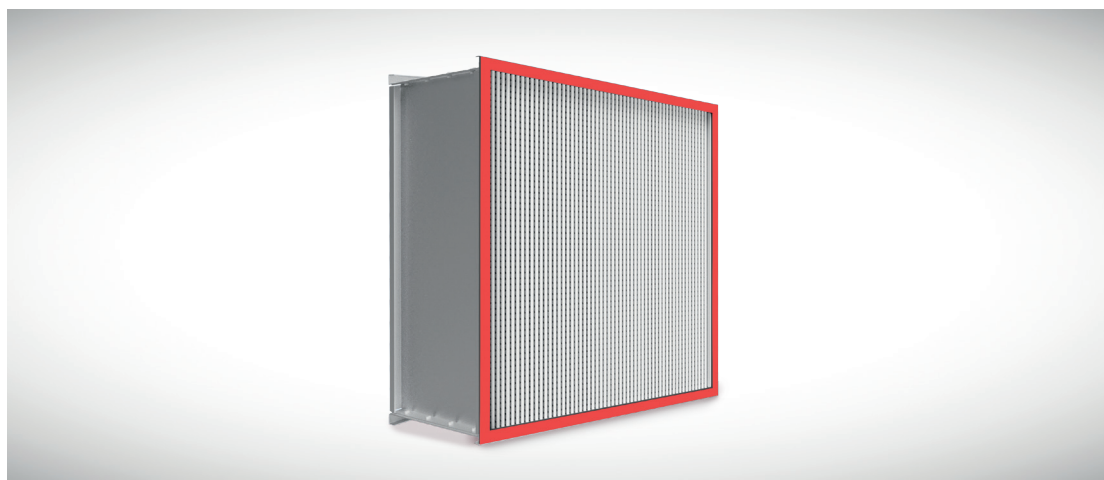

MICROBARRIER HEPA HT & HEPAMAX HT SEPARATOR STYLE FILTERS FOR CRITICAL APPLICATIONS

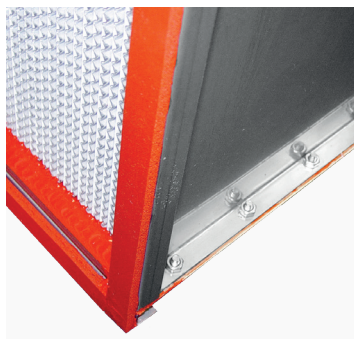

Close-up of Microbarrier HEPA HT
frame media pack & sealant

MANN+HUMMEL Air Filtration Americas' Microbarrier HEPA HT & HEPAMAX™ HT filters are designed for the challenging environments of high temperature applications where high demands are placed on HEPA filters. Microbarrier HEPA & HEPAMAX™ high temperature filters are rated up to 500 °F (260 °C). MANN+HUMMEL's quality controlled manufacturing facility ensures that you receive the highest quality products.

Microbarrier HEPA HT & HEPAMAX™ HT filter media packs are constructed utilizing a moisture resistant, glass microfiber. The Microbarrier HEPA HT & HEPAMAX™ HT media pack is supported by aluminum separators that are rolled and tapered and placed between each pleat to maximize performance, ensure maximum air flow at minimum resistance and to protect the media pack.

HEPA filters are tested for leaks in the media pack and in the seal between the media pack and frame. Microbarrier HEPA HT filters provide particle removal efficiencies of 99.97% and 99.99% .

Microbarrier HEPA HT & HEPAMAX™ HT filters are available in a gasket seal model. The standard gasket is a ¼" x ¾" silicone sponge gasket that can handle temperatures up to 500 °F (260 °C).

The Microbarrier HEPA HT & HEPAMAX™ HT filters utilize a high temperature silicone sealant. This silicone compound sealant is rated up to 500 °F (260 °C) of continual service.

Microbarrier HEPA HT/ HEPAMAX™ HT

Technical Specifications

MICROBARRIER HEPA HT DRAWING

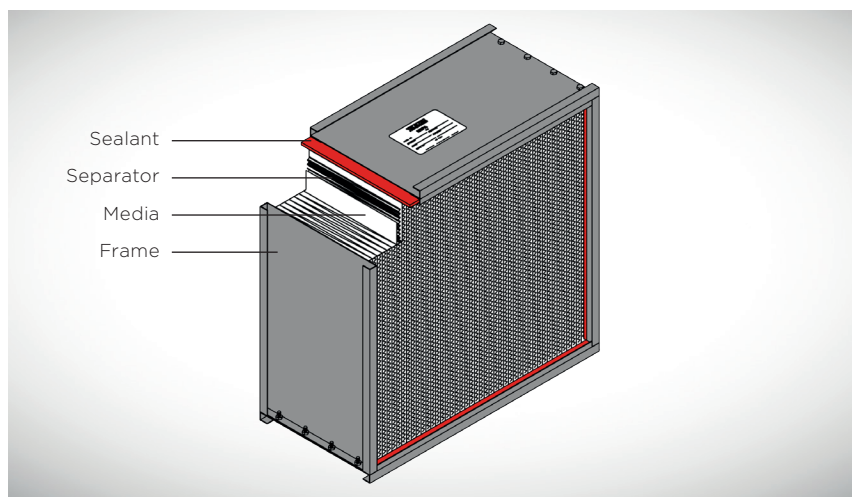

Microbarrier HEPA HT & HEPAMAX™ HT filters use a stainless steel frame that is bolted together for added strength and rigidity required for demanding environments where high temperature filters are utilized.

Microbarrier HEPA HT & HEPAMAX™ HT are available in standard capacity and a high flow capacity model. The HEPA HT standard capacity model is rated at 250 FPM at 1.0" w.g. of resistance. The high flow model, with 80% more media than our standard model, is rated at 500 FPM at 1.4" w.g. of resistance.

TECHNICAL DATA

Product	MICROBARRIER HEPA HT	MICROBARRIER HEPAMAX™ HT
Recommended Air Flow	250 FPM (1.3 m/s)	500 FPM (2.5 m/s)
Resistance	1.0" w.g. (249 PA)	1.4" w.g. (348 PA)
Temperature Limit	500 °F (260 °C)	500 °F (260 °C)
Frame Construction	Stainless steel	Stainless steel
Sealant	Silicone compound	Silicone compound
Standard Efficiencies	99.97% & 99.99%	99.97% & 99.99%

MANN+HUMMEL is committed to continual product development – all descriptions, specifications and performance data are subject to change without notice. MANN+HUMMEL products are manufactured to exacting criteria – there can be a ±5% variance in filter performance.

LOCAL REPRESENTATIVE